

Stainless Steel Wall Mount Food Grade Channel

Features:

- Manufactured in heavy-duty 12 gauge type 304 stainless steel
- Polished to a bright, easily maintainable finish that is modern, attractive, easy to clean, and that also enhances the surface's resistance to pitting & bacterial corrosion
- May be installed vertically or horizontally
- Available in multiple pre-cut lengths



Applications:

The Calbrite system of metal framing is based on the use of a continuous slotted channel, and a series of brackets and fittings, which can be fastened to it at any point. With Calbrite channel and components, racks, supports for conduit, wiring, and electrical equipment, machine frames, and a limitless variety of structures can be built rapidly, simply, and economically. Food Grade Channel is designed specifically for wash-down applications or damp environments, to prevent contaminants or bacteria build-up.

Industries Commonly Served:

- Food & Beverage Production & Distribution
- Chemical Plants
- Water & Wastewater Treatment
- Pharmaceuticals & Cosmetics
- Refining & Extraction Sites
- Petrochemical
- Pulp & Paper Mills
- Marine & Coastal Facilities
- Along with other corrosive environments

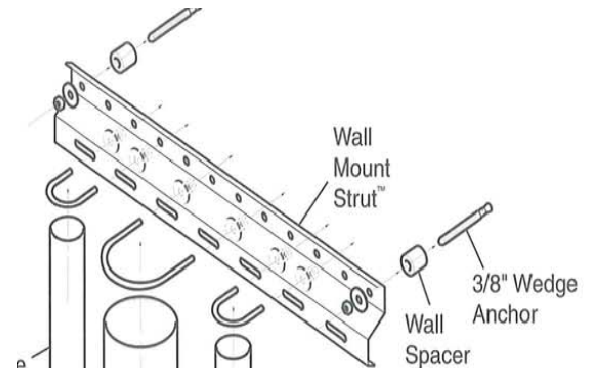

12" Length Part Number	24" Length Part Number	120" Length Part Number	Slotted Hole Length	Slotted Hole Width	Overall Width	Weight (lbs) per ft.
S4FG12STWM	S4FG24STWM	S4FG10STWM	1.070"	0.030"	4.00"	1.72

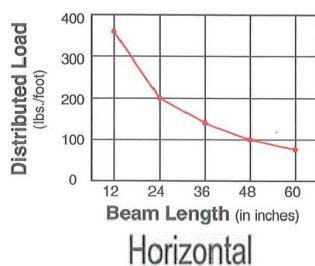
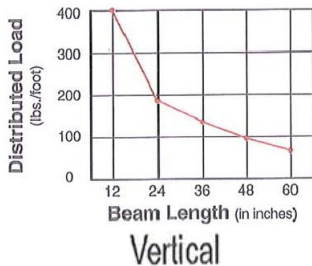

All dimensions are for informational purposes only *Tolerances +/- 5%